

Gardner Denver

5-40 HP | OIL-LESS | ROTARY SCROLL COMPRESSOR

EnviroAire ES



PureAir
ISO CLASS ZERO PLUS ULTRA-DRY



**Gardner
Denver**

ENVIROAIRE ES15 D

Legendary Experience

Innovative Design

Gardner Denver has over 150 years of experience in manufacturing the highest quality compressors. The EnviroAire rotary scroll system is the perfect example of our progressive innovation.

Oil-less compressors have become a standard in industries such as medical, lab/research, biotechnology, pharmaceutical, food & beverage, and semiconductor. Oil contamination is extremely detrimental to these processes. Pure air quality demands are rapidly growing with new regulations and laws regarding oil contamination throughout multiple industries and applications. Gardner Denver has designed the EnviroAire Scroll compressor specifically for these applications that require **100% OIL-FREE AIR**.

- Extremely Quiet Operation
- Fewer Moving Parts, Low Maintenance & High Reliability
- Environmentally Friendly Contaminate Free Air

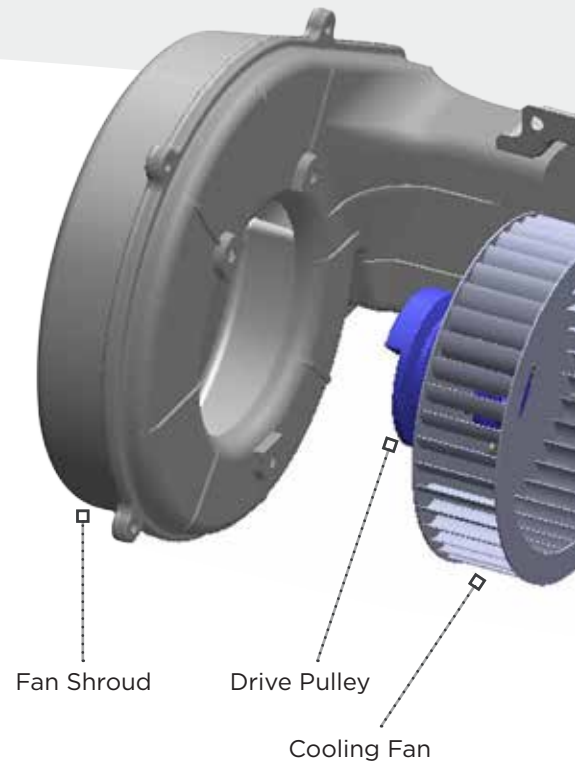

Scroll Compression Explained

- An orbiting (rotating) scroll and fixed scroll housing are mated to create the compression chambers
- The continual movement of the orbiting scroll moves atmospheric air from the intake toward the center, compressing the air into progressively smaller areas
- The compressed air is directed to the center discharge port of the compressor

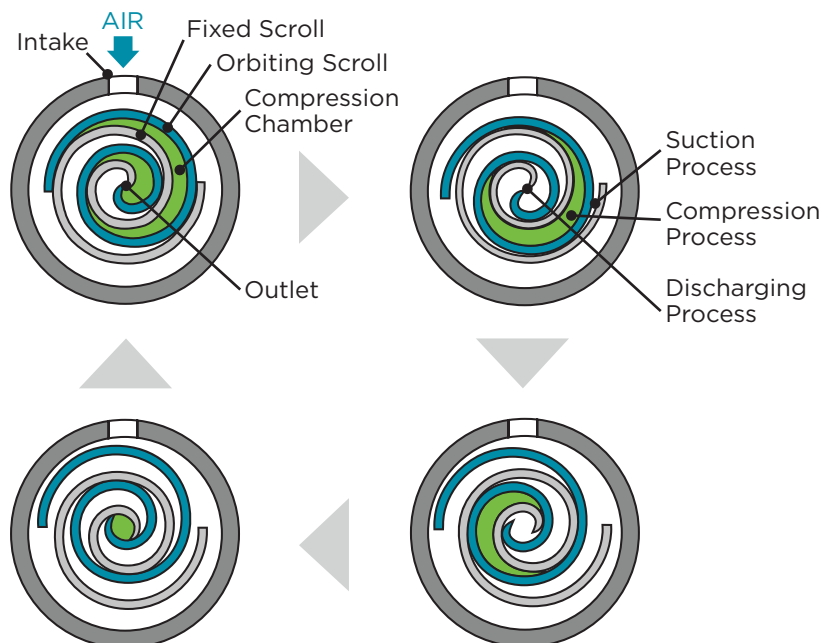

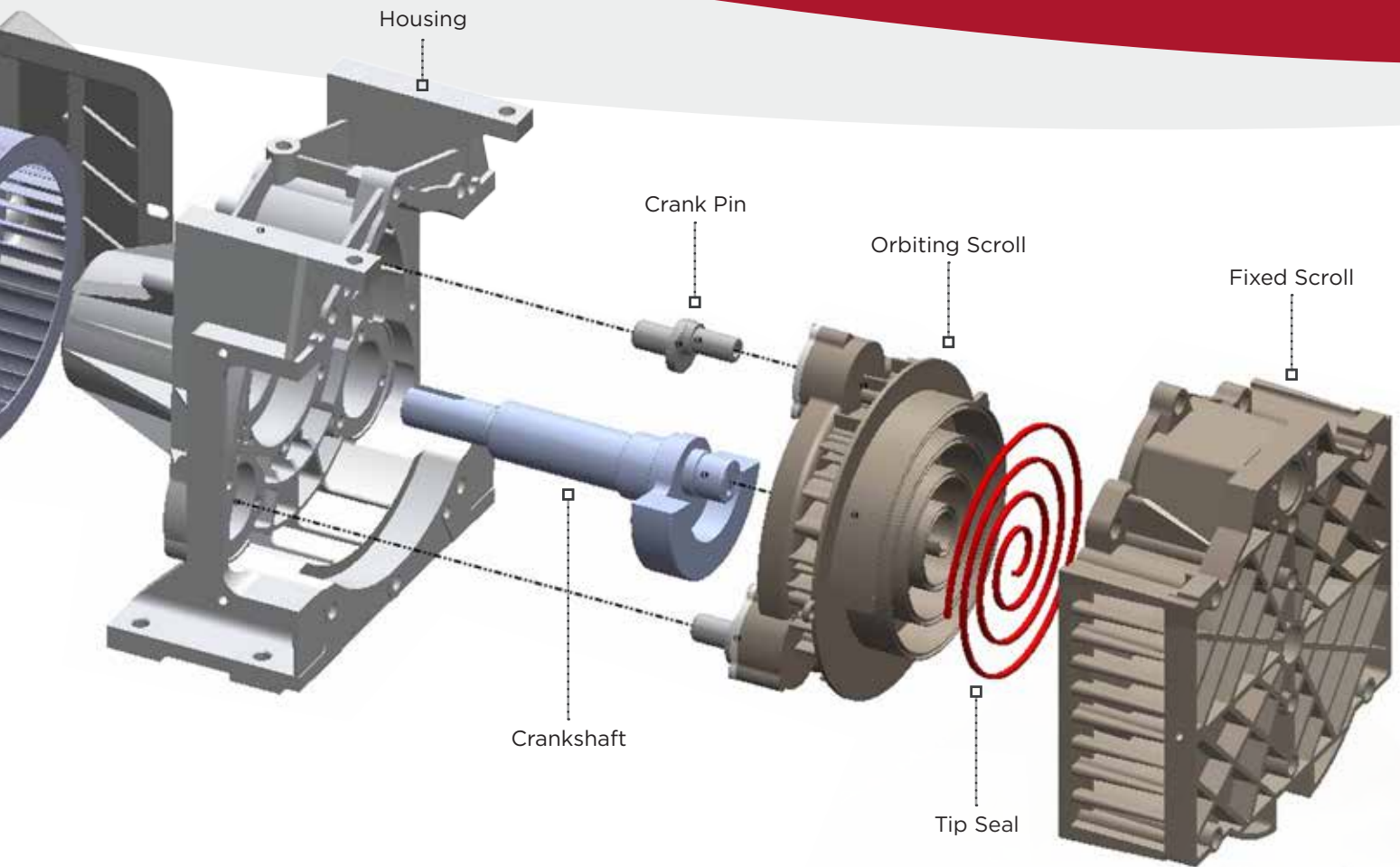

Scroll Compressor Features

- 100% Oil-Less Design
- Oil-Free/Contaminant Free Air
- Continuous Operation, 100% Duty Cycle
- Integral Cooling Fan
- 116 or 140 PSI Options
- Low Sound Levels
- Low Vibration
- Compact Footprint
- 5 to 40 HP Package Options
- Flow from 13.7-124 CFM @ 116 PSI
- Low Maintenance and High Reliability
- Fewer Moving Parts than Recip or Screw



PureAir

ISO CLASS: ZERO PLUS SILICONE FREE

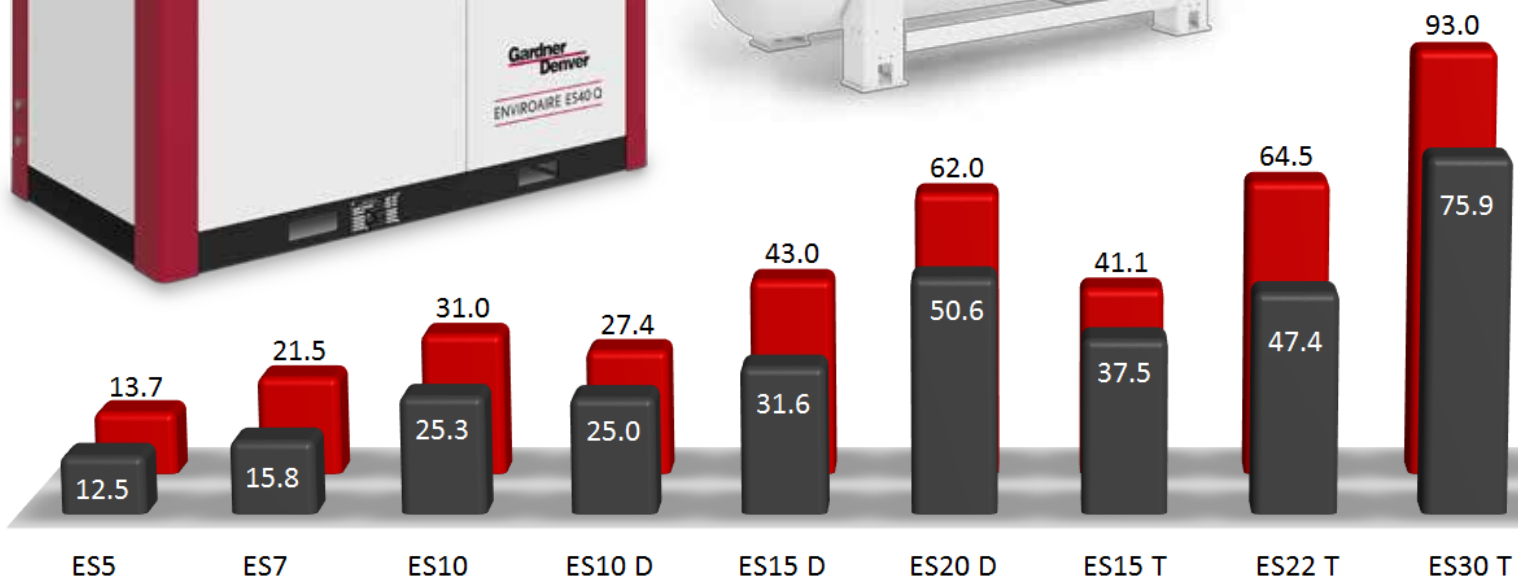

SIMPLEX

DUPLEX

TRIPLEX

(ACFM) ■ 140 PSI ■ 116 PSI

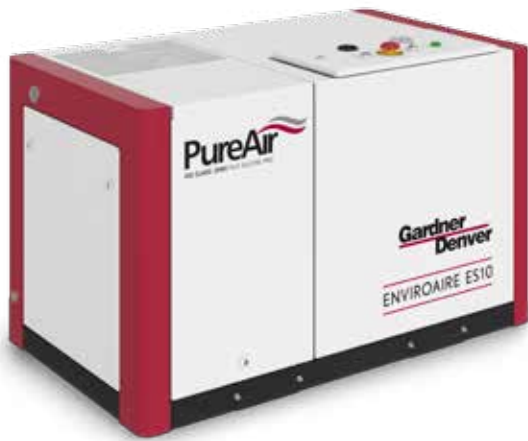

A Superior Compressor Package

Gardner Denver designed a solution to lower sound levels for noise sensitive environments, while at the same time meeting the strict requirements for contaminant free, oil-free, and clean air applications. The EnviroAire ES compressor has a very clean, simple, and serviceable layout while maintaining the robust quality expected from Gardner Denver. When dependability and longevity are determining factors in your clean air application, Gardner Denver has the right product for you.

EnviroAire ES

The enclosed scroll product line starts with simplex units at 5, 7.5, and 10 HP, available as base mounted or factory mounted on a 30, 80, or 120 gallon receiver. The EnviroAire ES is the perfect choice for a compact, efficient, and low maintenance option in a wide variety of clean air applications. Base mounted multiplex packages range from 10 to 40 horsepower in configurations of Duplex, Triplex, or Quadraplex in a single sound attenuating enclosure for quiet operation. These units provide peace of mind with the redundancy of additional compression elements, and support energy efficiency by controlling the number of compressor elements in operation to meet current air demand.

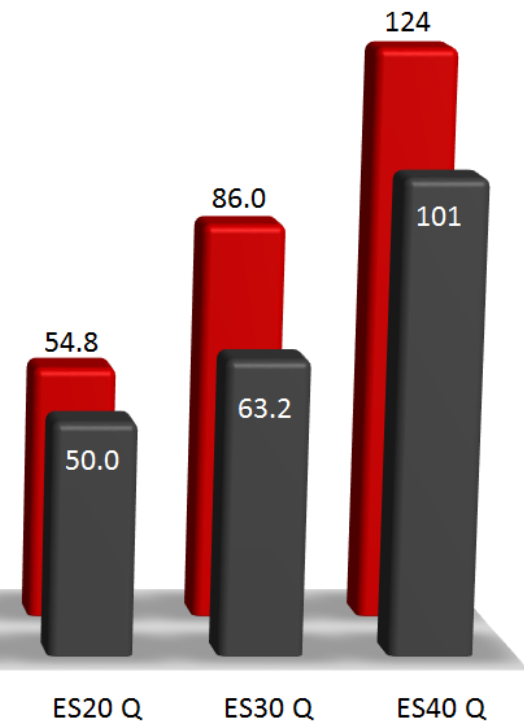

QUADRAPLEX

SIMPLE

Savings

User Friendly

QUIET

RELIABLE

Oil-Less

Premium Technology

EnviroAire ES

- 1 Automatic Condensate Drain
- 2 Rigid Framework
- 3 5 Micron Inlet Filter
- 4 Fork Slots for Easy Handling
- 5 Unique Chambered Design - Maximized Cooling and Serviceability
- 6 Large Industrial Aftercoolers
- 7 Premium Efficient TEFC Motor
- 8 High Volume Cooling Fan
- 9 Sound Attenuating Enclosure
- 10 Internal Vibration Isolators



QUALITY Efficient Superior Design
Oil-Free Air Contaminant Free
SERVICEABLE Clean Air



System Controls

The EnviroAire ES integrated control system protects your compressor and ensures reliable operation. Simplex units feature a user friendly relay panel equipped with basic controls to start/stop the unit automatically as the set pressure is reached. The Deluxe HMI controller from Gardner Denver is an optional upgrade to the simplex product offering, and is a standard feature on the duplex, triplex, and quadraplex packages. Easy to use navigation and user friendly graphics deliver interactive and intuitive monitoring information at your fingertips. The monitoring features enhance both product reliability and operational efficiency. With an integral webserver, via Modbus TCP Ethernet connection, the Deluxe HMI controller provides visibility to the EnviroAire scroll compressor system from any computer or mobile device with an internet connection.

Deluxe HMI

- 3.5" Full Color Touch Screen
- PLC Controlled
- Lead/Lag Control with Forced Alternation
- System Capacity and Operation Trending
- 26 Language Options
- 24VDC Power Supply with Fusing
- System Run Time Meter
- Alarm/Fault Log
- System Discharge Pressure
- Pump Discharge Temperature
- System Maintenance Timers
- Integral Webserver
- Modbus TCP Interface over Ethernet

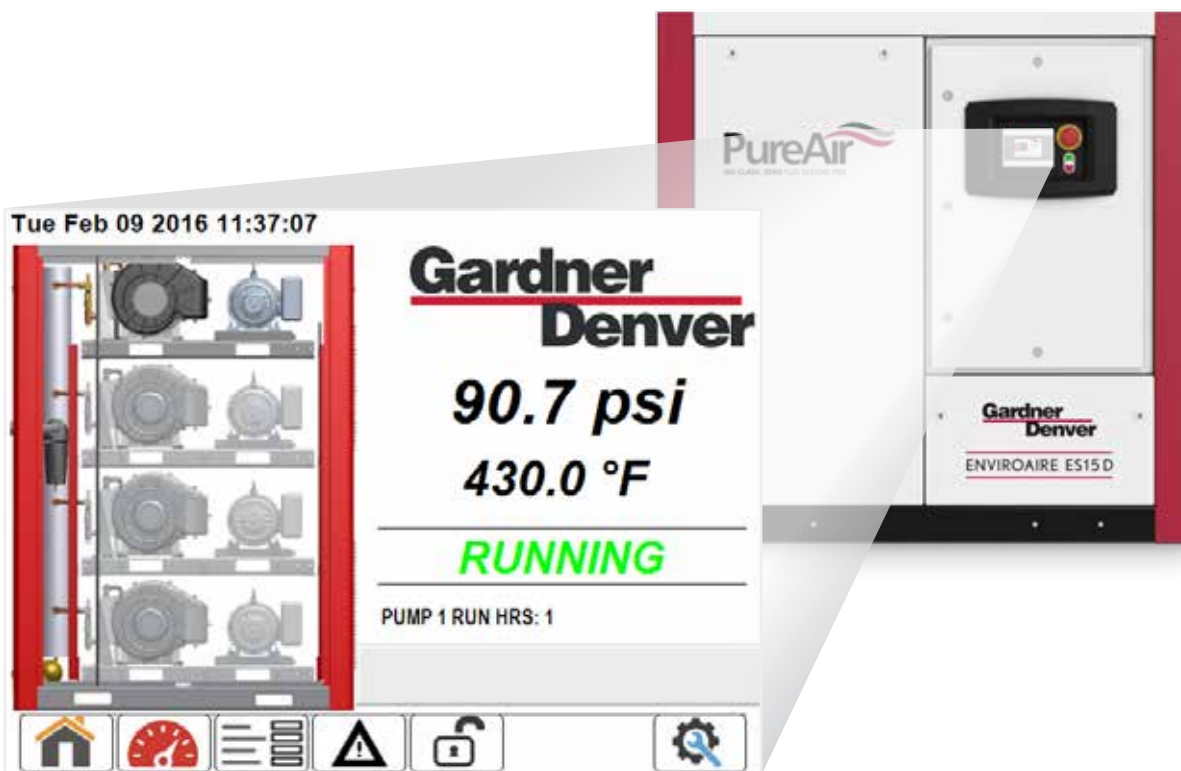

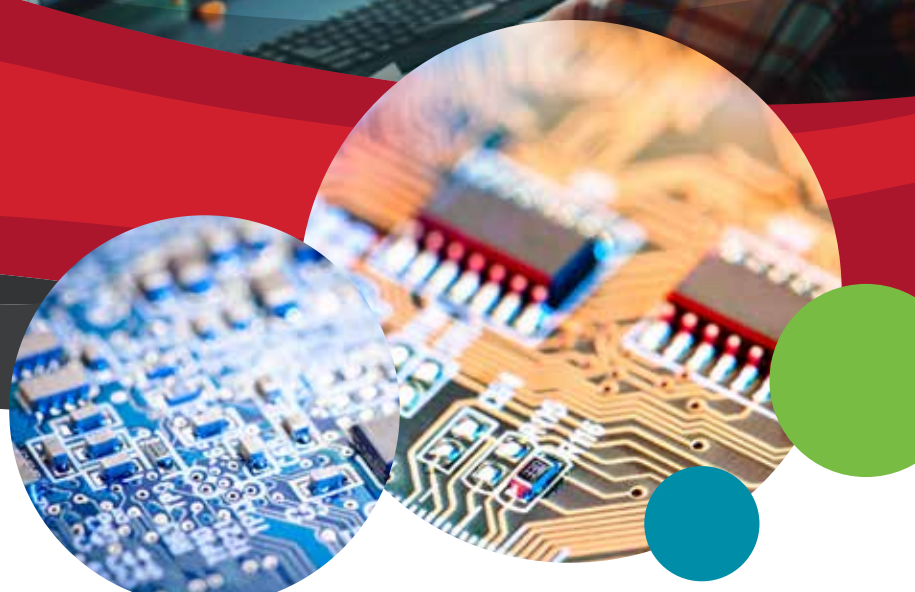

Simplex Basic Relay Panel

- NEMA 1, UL508A Labeled Panel
- Magnetic Contactor with Overload Protection
- 115V Control Circuit Transformer with Fusing
- Door Mounted TOA Switch
- Emergency Stop Button
- Green Power On Light
- Run Time Meter
- Pressure Gauge
- Reset Button

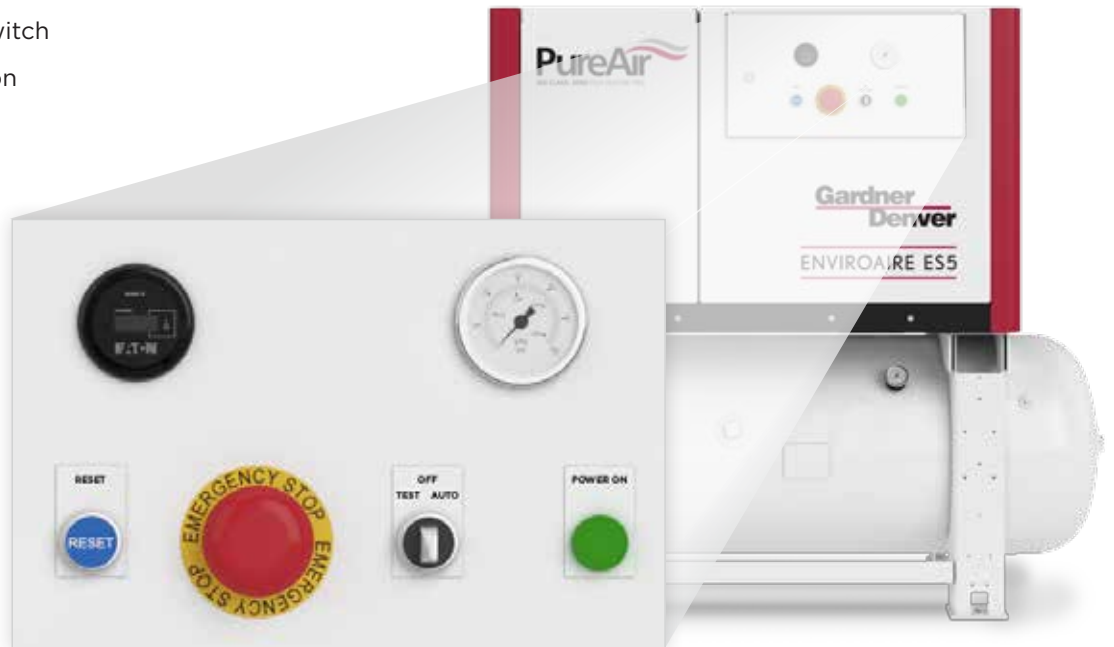

EnviroAire ES Specifications

MODEL	MOTOR HP × QTY	TOTAL HP	TOTAL KW	APPROX. SHIP WEIGHT		NOISE LEVEL DB(A)	MAX. WORKING PRESSURE			
				LBS.	KG		116 PSI ACFM	8 BAR M ³ /HR	140 PSI ACFM	10 BAR M ³ /HR
ES5	5 × 1	5	4	695	315	65	13.7	23.3	12.5	21.2
ES7	7.5 × 1	7.5	6	775	351	70	21.5	36.5	15.8	26.8
ES10	10 × 1	10	8	810	367	73	31.0	52.7	25.3	43.0
ES10 D	5 × 2	10	8	1240	562	64	27.4	46.6	25.0	42.5
ES15 D	7.5 × 2	15	11	1320	598	68	43.0	73.1	31.6	53.7
ES20 D	10 × 2	20	15	1355	614	71	62.0	105.3	50.6	86.0
ES15 T	5 × 3	15	11	1386	629	69	41.1	69.8	37.5	63.7
ES22 T	7.5 × 3	22.5	16	1624	737	66	64.5	110	47.4	80.5
ES30 T	10 × 3	30	22	1713	777	69	93.0	158	75.9	129
ES20 Q	5 × 4	20	15	1535	696	70	54.8	93.1	50.0	85.0
ES30 Q	7.5 × 4	30	22	1853	841	67	86.0	146	63.2	107
ES40 Q	10 × 4	40	30	1972	894	70	124	211	101	172





DIMENSIONS	IN.			MM		
	L	W	H	L	W	H
Simplex Base Mount	46	30	28	1168	762	711
30 Gallon Horizontal	48	30	49	1219	762	1245
80 Gallon Horizontal	66	30	53	1677	762	1347
120 Gallon Horizontal	70	30	57	1778	762	1448
Duplex Base Mount	52	34	55	1321	864	1397
Triplex Base Mount	65	34	77	1651	864	1956
Quadraplex Base Mount	65	34	77	1651	864	1956



Eliminate the Risk

Guaranteed 100% Oil-Free

The EnviroAire ES is a 100% Oil-Less design. There is no oil present anywhere in the compressor package, which completely eliminates the risk of product contamination due to oil carryover. The EnviroAire ES meets ISO 8573-1 Class 0, the most stringent class. It is also certified Silicone-Free which is critical for applications such as automotive and pharmaceutical.

CLASS	CONCENTRATION TOTAL OIL (AEROSOL, LIQUID, VAPOR) MG/M ³
0	As specified by the equipment user or supplier and more stringent than class 1
1	≤ 0.01
2	≤ 0.1
3	≤ 1
4	≤ 5

Silicone-Free

Silicone contamination in compressed air systems cause problems across a wide range of industries such as electronics, pharmaceuticals and automotive. Costly product spoilage, re-work and production downtime can result from this contamination.

For example, a high quality paint finish is essential to the automotive industry. Blisters, cracks, craters and loss of adhesion are all symptoms of silicone contamination.

- 100% silicone-free, guaranteed
- Specifically designed for use in pure-air critical applications such as the automotive, food and beverage, pharmaceutical, laboratory, and medical industries
- Avoids contamination and provides the highest air quality standards
- Independently tested and certified



PureAir

ISO CLASS: ZERO PLUS SILICONE FREE

Gardner Denver—the Total Package

Dryers, Filtration & Downstream Equipment

Compressed air systems require clean dry air with environmentally sound disposal of by-products. That is why Gardner Denver support does not stop at the compressor. Proper removal of contaminants is essential in preventing costly damage to equipment. Gardner Denver provides a broad range of dryers, filters, separators, drains, and other downstream products to ensure total system reliability. Shown below are some typical applications and general product arrangements.

Pneumatic Tools



Spray Painting

Food & Beverage

Laboratory

Pharmaceutical

High Tech Laboratory

Medical Equipment

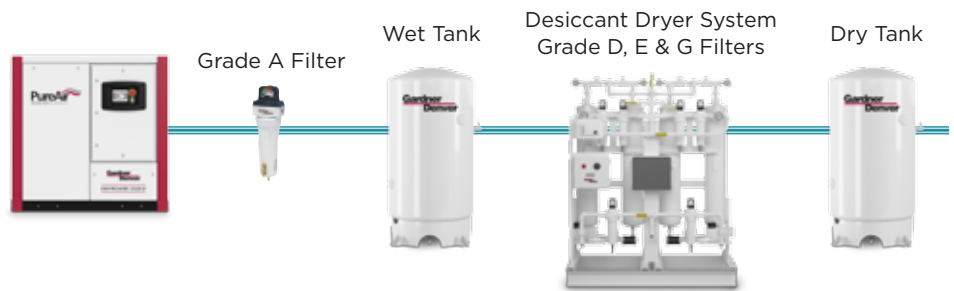

Sales & Service **Distributors** Across America

An Extensive Network

By leveraging the extensive network of Gardner Denver factory-trained authorized local distributors—your sales, service, and technical support needs can be handled quickly and easily.

To find a distributor visit:

<http://gardnerdenverproducts.com>



The leader in every market we serve
by continuously improving all business processes
with a focus on innovation and velocity

**Gardner
Denver**[®]

Gardner Denver, Inc.

1800 Gardner Expressway
Quincy, IL 62305
866-440-6241

www.gardnerdenver.com/gdproducts



©2017 Gardner Denver, Inc. Printed in U.S.A.
GL-ENVIROAIRE-ENCL 1st Ed. 8/17

 Please recycle after use.